

ZOLLERN

Solid metals. Fine solutions.

Drive Technology

Slewing gears



The ZOLLERN-Group

With first-class products and customized solutions in the sectors drive technology, investment casting, sand casting and forging as well as steel profiles we are one of the leading manufacturers – worldwide.

As one of the oldest family-run businesses in Germany we are proud to look back on an impressive 300-year history during which we have merged tradition with innovation. Our main focus is on excellent quality and service.

Welcome to the world of ZOLLERN, where experience and progress go hand in hand to offer our customers the best solutions and products for their requirements in various industrial sectors.

Content	Side
Slewing Units	3
Features and design	4
Gear unit selection	9
Application Factor k	10
Classification guidance	10
Technical Data	12
Installation instructions	16
Gear reduction ratios	17
Recommended lubricants	19
Application Questionnaire	20
Remarks and special operating conditions	21
ZOLLERN Group Product areas	22

Slewing Units



ZOLLERN Slewing Units

have proved highly successful under extreme operating conditions. Their principal features and most significant advantages are

- compact dimensions
- long operation life
- modular design of gear unit
- ease of maintenance
- high performance
- functional design

With these characteristics the machine designer will get a ready to install unit and will achieve economic solutions even in confined space conditions.

Potential applications

- mobile cranes
- material and working elevators
- shipboard and deck cranes
- dockyard and harbour cranes
- container gantries
- yaw & pitch drives for wind turbines
- construction cranes and conveyors
- loading and cargo handling cranes
- rescue and wrecker salvage trucks
- offshore cranes
- access platforms

ZOLLERN gears use components common to our complete range (Winches, Slewing Units, Industrial Gears, Free Fall Winches) giving the advantage of volume production: cost savings from standard parts, reduced lead times, tested and proven designs across the whole range and readily available spares for units in service.

Features and design

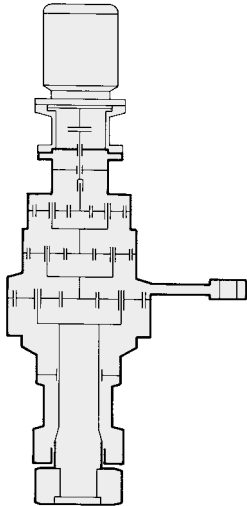

Coaxial design
Three planetary stages
Ratios $i = 46$ to 177
Drive by electric motor
Long output shaft
Fastening by reaction torque arm
Input shaft and output shaft have the same direction of rotation

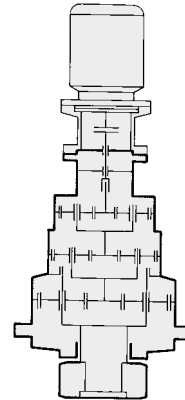

Coaxial design
Three planetary stages
Ratios $i = 46$ to 177
Drive by electric motor
Short output shaft
Input shaft and output shaft have the same direction of rotation.

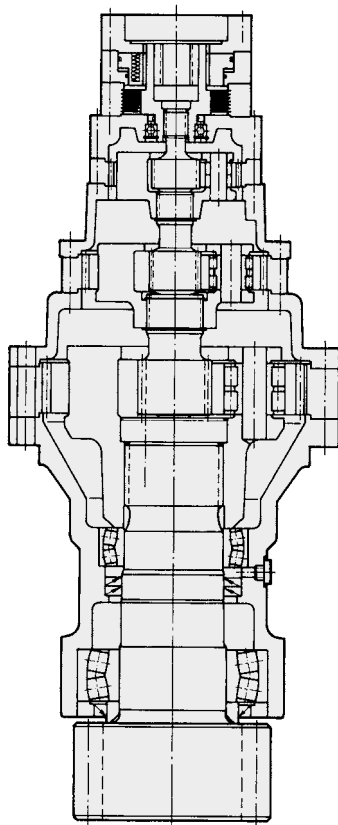

Slewing Unit

Output torques from 1.400 to 1.550.000 Nm Ratios $i = 17$ to 1.209 (other ratios available on request).
When determining the torque, the acceleration and the deceleration as well as wind effect and other induced loads must be taken into consideration (see page 9).

Rating

The output torques $T_{dyn\ max}$ mentioned in table page 10 refer to FEM I 3rd edition, collective load L2, duty cycle class T5, corresponding to 'transmission group M5'. Ambient temperature $+ 20^{\circ}\text{C}$.
(FEM-Fédération Européenne de la Manutention).

Gear teeth design

Optimized for best possible tooth flank and root load capacity and minimum sliding speeds in accordance with DIN 3990. Externally toothed gears case hardened and ground, internal gears heat-treated and nitrided.

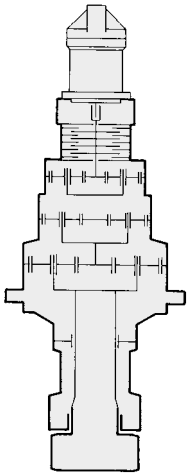

**Coaxial design
Three planetary stages**

Ratios $i = 46$ to 177
 Drive by hydraulic motor
 Long output shaft
 Input shaft and output shaft
 have the same direction of
 rotation.

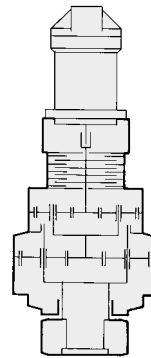

**Coaxial design
Two planetary stages**

Ratios $i = 17$ to 35
 Drive by hydraulic motor
 Short output shaft
 Input shaft and output shaft
 have the same direction of
 rotation.

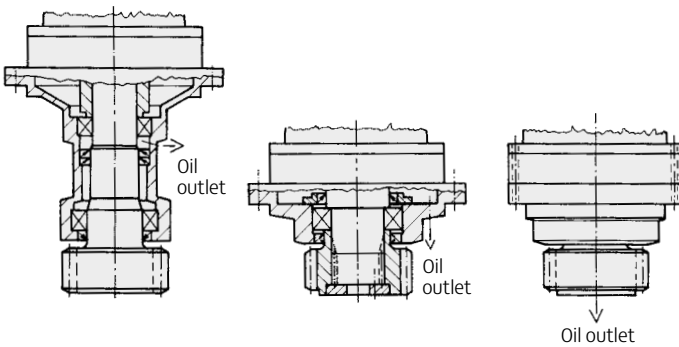

Lubrication

All gears and anti-friction bearings are splash lubricated. Output bearings are grease packed for lifetime operation –requiring no further service attention. Service intervals and recommended lubricants are given in the table on page 15. Oil level is checked by either dip stick or sight glass.

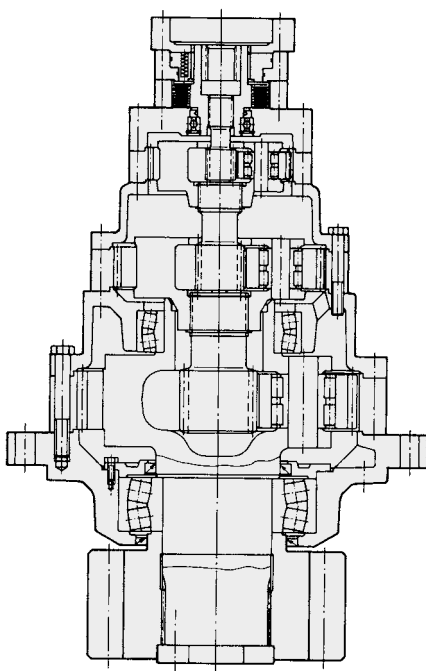

Efficiency

The efficiency per planetary stage is 98 % and for the output shaft bearing including sealing 99 %.
 Example: Slewing gear with 2 planetary stages
 $\eta_{total} = 0,98 \times 0,98 \times 0,99$
 $= 0,95$

Bearings

All components carried in antifriction bearings. Needle roller bearings and cylindrical roller bearings in the planetary wheels. Generously dimensioned self aligning roller bearings in the output shaft housing, supporting the pinion.

Installation

Vertical or horizontal as specified

Features and design

Seals

The input is sealed by a radial shaft sealing ring with a dust lip

- a) by two radial shaft sealing rings
- b) by the grease packing in the output shaft housing
- c) by another radial shaft sealing ring

so that safe protection against oil loss and against penetration of dirt and water is assured.

Input Options

ZOLLERN's modular system provides for hydraulic or electric motor input interfaces. Flange mounted or free shaft with key to DIN 5480.

Parking brake

Amplly dimensioned spring-applied multi-disc parkingbrake, hydraulically released, to hold the slewing mass and to brake the slewing mass in case of emergency. Not to be used as a service brake.

Pressure	min. 15 bars max. 250 bars
Back pressure	max. 0,5 bar allowed

Please consult us if back pressure value exceeds this figure. Connecting line 8 x 1 tubing to DIN 2391 C, as short as possible.

Service brake to hold and brake the slewing mass, hydraulically, pneumatically or mechanically operated (optional extra).

Eccentric adjustment

For accurate adjustment of backlash between the output pinion and the driven ring gear, the output shaft assembly can be provided with eccentric adjustment in relation to the flange and output pinion.

Eccentricity	Flange I $x = 2,5$ Flange II $x = 1,5$ Flange III $x = 1,5$
--------------	---

Painting Primer

This is a specially developed multi-primer with a two-component zinc-dust epoxy resin base. Colour: Grey white. A two component epoxy resin is most suitable for the finish coat.

Output pinion

Addendum modification coefficient
 $x = + 0,5$
Gear cutting quality 9e
Tip relief

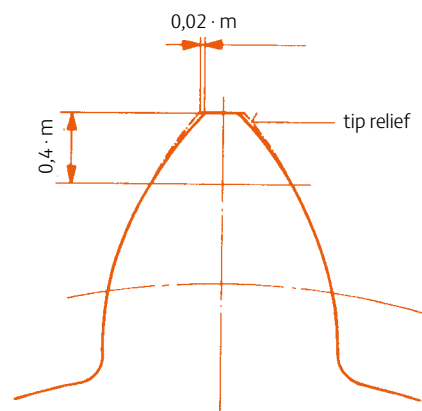

Output Pinion Options

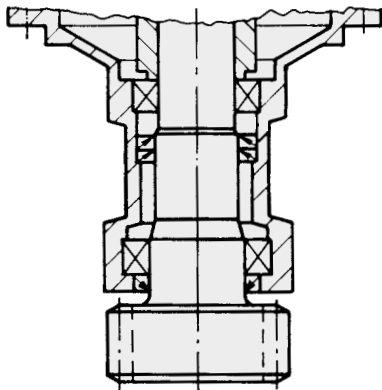

Forged one piece pinion shaft – standard

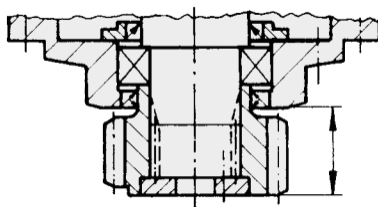

Splined Output Shaft
Pinion fitted with splines to DIN 5480.

Output Pinion Specification

Tough 42CrMo4V hardened gear steel tempered to 700–900 N/mm² Teeth surface hardened HRC 57+7 (Case hardened Pinions with ground gearing available on request)

Selection of gear unit size

In order to determine the correct gear unit for a given application, the output torque T_{dyn} has to be multiplied with the factor k , page 10.

$$T_{nom} = T_{dyn} \times k \leq T_{dyn_{max}}$$

Working conditions

The slewing gears are designed for operation in European conditions or similar. Permissible oil temperatures -20°C to +70°C.

Working environment such as salt water, high salt level in air, dust, sludge, flying stones, overpressures, severe vibration or shock, excessive ambient temperatures or aggressive media have to be specified.

Gear unit mounting

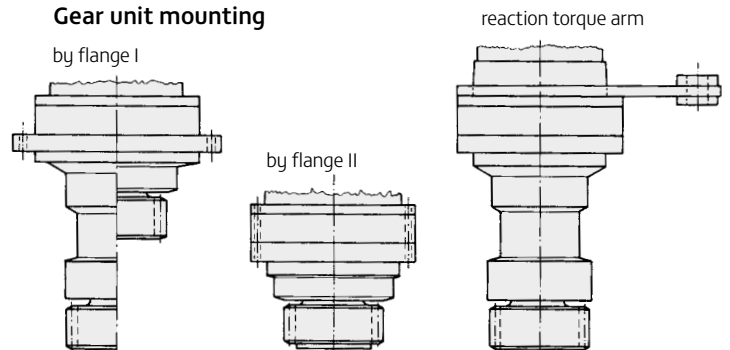



Gear unit selection

Determination of the imposed maximum torques on the output pinion of the slewing gear unit can only be undertaken with the exact knowledge of the general view.

The following has to be considered acc. to section I, 3rd edition 1998

- S_{MF} = maximum torque due to frictional forces
- S_{MW8} = maximum torque due to wind effect 80 N/m²
- S_{MS} = maximum torque due to inclined position
- S_{MA} = maximum torque due to acceleration
- S_{MW25} = maximum torque due to wind effect 250 N/m²
- γ_m = amplifying coefficient of loading depending on mechanism group factor

Regular service without wind effect

$$S_{M \max I} = (\bar{S}_{MF} + \bar{S}_{MA}) \gamma_m$$

S_{MF} = greatest value, \bar{S}_{MF} = average value

Regular service with wind effect

$$S_{M \max II} = (\bar{S}_{MF} + \bar{S}_{MA} + \bar{S}_{MW8}) \gamma_m$$

$$S_{M \max II} = (\bar{S}_{MF} + \bar{S}_{MW25}) \gamma_m$$

Regular service with wind effect and inclined position

$$S_{M \max II} = (\bar{S}_{MW8} + \bar{S}_{MS}) \gamma_m$$

$S_{M \max}$ is the result of the most unfavourable combination of torques which may occur at the same time but not the sum of the maximum individual values.

Application Factor k for slewing gears

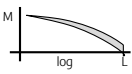
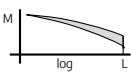
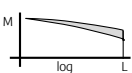
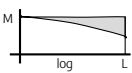
Running time classification	Symbol	T2	T3	T4	T5	T6	T7	T8
	Mean running time per day in hours, related to one year		over 0,25 to 0,5	over 0,5 to 1	over 1 to 2	over 2 to 4	over 4 to 8	over 8 to 16
Life in hours 8 years, 200 days/year		400 to 800	800 to 1.600	1.600 to 3.200	3.200 to 6.300	6.300 to 12.500	12.500 to 25.000	25.000 to 50.000
Load conditions	Collective coefficient k_m	Drive unit class Application Factor k						
L1	 to 0,125	M1 0,90	M2 0,93	M3 0,95	M4 1	M5 1,07	M6 1,18	M7 1,24
L2	 0,125 to 0,250	M2 0,93	M3 0,95	M4 1	M5 1	M6 1,14	M7 1,24	M8 1,48
L3	 0,250 to 0,500	M3 1	M4 1,05	M5 1,13	M6 1,18	M7 1,25	M8 1,48	M8 1,67
L4	 0,500 to 1.000	M4 1,25	M5 1,3	M6 1,4	M7 1,48	M8 1,52	M8 1,65	M8 1,97

Classification guidance

According FEM section I 3rd edition, table T.2.1.3.5.

Type of appliance Designation	Particulars concerning nature of use (1)	Type of mechanism				
		Hoisting	Slewing	Luffing	Traverse	Travel
Erection cranes		M2 - M3	M2 - M3	M1 - M2	M1 - M2	M2 - M3
Stocking and reclaiming transporters	Hook duty	M5 - M6	M4	-	M4 - M5	M5 - M6
Stocking and reclaiming transporters	Grab or magnet	M7 - M8	M6	-	M6 - M7	M7 - M8
Workshop cranes		M6	M4	-	M4	M5
Overhead travelling cranes, pigbreaking cranes, scrapyard cranes	Grab oder magnet	M8	M6	-	M6 - M7	M7 - M8
Bridge cranes for unloading, bridge cranes for containers Other bridge cranes (with crab and/or slewing jib crane)	a) Hook or spreader duty b) Hook duty	M6 - M7 M4 - M5	M5 - M6 M4 - M5	M3 - M4 -	M6 - M7 M4 - M5	M4 - M5 M4 - M5
Bridge cranes for unloading, bridge cranes (with crab an/or slewing jib crane)	Grab or magnet	M8	M5 - M6	M3 - M4	M7 - M8	M4 - M5
Drydock cranes shipyard jib cranes, jib cranes for dismantling	Hook duty	M5 - M6	M4 - M5	M4 - M5	M4 - M5	M5 - M6
Dockside cranes (slewing, on gantry, etc.), floating cranes and pontoon derricks	Hook duty	M6 - M7	M5 - M6	M5 - M6	-	M3 - M4
Dockside cranes (slewing, on gantry, etc.), floating cranes and pontoon derricks	Grab or magnet	M7 - M8	M6 - M7	M6 - M7	-	M4 - M5
Floating cranes and pontoon derricks for very heavy loads (usually greater than 100 t)		M3 - M4	M3 - M4	M3 - M4	-	-
Deck cranes	Hook duty	M4	M3 - M4	M3 - M4	M2	M3
Deck cranes	Grab or magnet	M5 - M6	M3 - M4	M3 - M4	M4 - M5	M3 - M4
Tower cranes for building		M4	M5	M4	M3	M3
Derricks		M2 - M3	M1 - M2	M1 - M2	-	-
Railway cranes allowed to run in train		M3 - M4	M2 - M3	M2 - M3	-	-
Mobile cranes	Hook	M3 - M4	M2 - M3	M2 - M3	-	-

Arbeitsplatz

73270



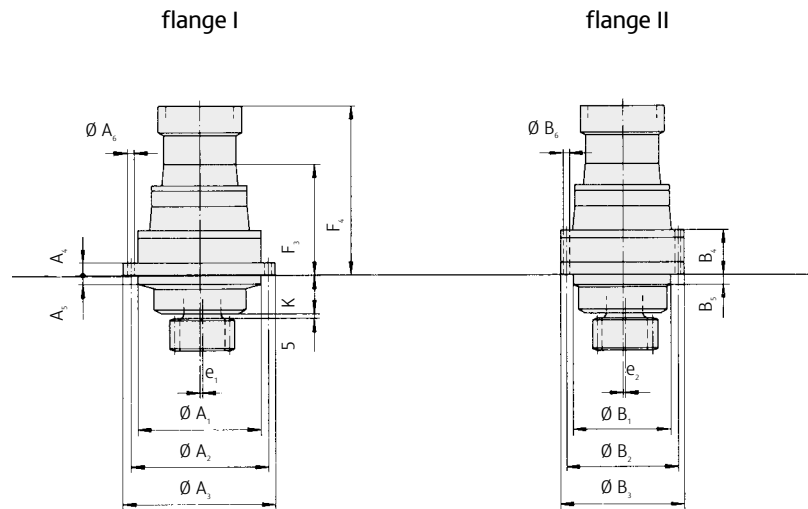

Nominal Output drive size ZHP

Hydraulic motor input

	K	H ₁	H ₂	L _{min.}	L _{max.}	M _{min.} h ₇	N	F _{min.}	D _{1min.}	D _{2min.}	e ₁	e ₂	2-stage				3-stage				4-stage					
													F ₁	F ₂ ²⁾ appr.	F ₃	F ₄ ²⁾ appr.	F ₁	F ₂ ²⁾ appr.	F ₃	F ₄ ²⁾ appr.	F ₁	F ₂ ²⁾ appr.	F ₃	F ₄ ²⁾ appr.		
3.13	50	42	44	140	400	125	51	45	60	80	1,2	-	127	256	-	-	-	-	-	-	-	-	-	-	-	-
3.15	55	55	118	170	800	150	55	55	85	100	1,5	1,5	149	299	184	334	226	355	261	390	-	-	-	-	-	-
3.19	70	70	125	190	800	180	62	80	110	115	2,5	1,5	180	348	215	383	271	421	306	456	-	-	-	-	-	-
3.20	75	75	163	230	1.300	210	78	80	115	135	2,5	1,5	191	374	231	414	301	451	341	491	370	499	410	539	-	-
3.22	90	78	165	250	1.300	240	85	85	135	160	2,5	1,5	226	415	276	465	346	514	396	564	437	587	487	637	-	-
3.24	100	100	200	300	1.300	270	108	100	150	180	2,5	1,5	226	415	281	470	350	518	405	573	442	592	497	647	-	-
3.25	100	78	261	330	1.300	270	116	100	160	190	2,5	1,5	257	471	327	541	393	576	463	646	504	654	574	724	-	-
3.26	100	100	255	340	1.300	270	125	110	170	205	2,5	1,5	286	500	371	585	425	608	510	693	537	705	622	790	-	-
3.27	110	110	285	350	1.700	340	131	115	180	225	2,5	1,5	319	598	409	688	480	669	570	759	600	768	690	858	-	-
3.29	140	190	244	420	1.700	380	172	145	220	240	2,5	1,5	350	629	-	-	525	739	615	829	660	843	750	933	-	-
3.31	160	-	-	450	1.700	420	170	165	240	280	2,5	1,5	379	-	-	-	575	789	685	899	714	903	824	1.013	-	-
3.32	170	-	-	480	1.800	450	170	-	-	-	2,5	1,5	432	-	-	-	648	927	783	1062	796	1010	931	1.145	-	-
3.33	Available on request																									
3.34	Available on request																									
3.36	Available on request																									
3.38	Available on request																									
3.40	Available on request																									

²⁾ Changes possible depending on motor size



Technical Data

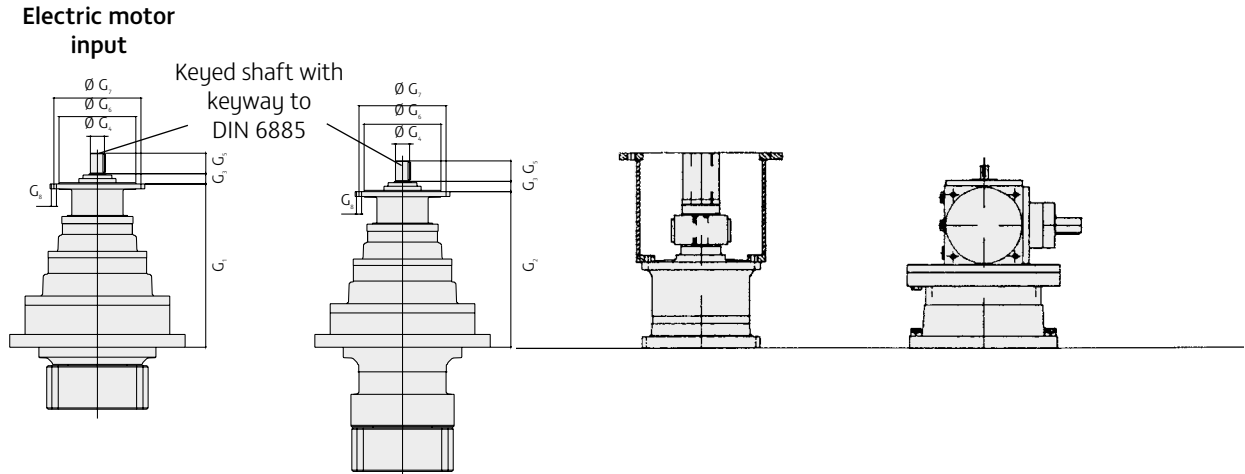

Nominal size ZHP Electric motor input

	2-stage								3-stage								4-stage							
	G ₁	G ₂	G ₃	G ₄ k ₆	G ₅	G ₆ h ₆	G ₇ ±0,2	G ₈	G ₁	G ₂	G ₃	G ₄ k ₆	G ₅	G ₆ h ₆	G ₇ ±0,2	G ₈	G ₁	G ₂	G ₃	G ₄ k ₆	G ₅	G ₆ h ₆	G ₇ ±0,2	G ₈
3.13	280	-	38	28	30	200	228	8*M12	-	-	-	-	-	-	-	-	-	-	-	-	-	-	-	-
3.15	284	319	38	38	45	250	280	8*M12	335	370	38	28	30	200	228	8*M12	-	-	-	-	-	-	-	-
3.19	314	349	38	42	50	250	280	8*M12	406	441	38	28	30	250	280	8*M12	457	492	38	28	30	200	228	8*M12
3.20	348	388	40	42	50	300	340	8*M16	434	474	38	38	45	250	280	8*M12	487	527	38	28	30	200	228	8*M12
3.22	381	431	40	48	56	300	340	8*M16	480	530	38	38	45	250	280	8*M12	572	622	38	28	30	250	280	8*M12
3.24	381	436	40	48	56	300	340	8*M16	480	535	38	38	45	250	280	8*M12	572	627	38	28	30	250	280	8*M12
3.25	440	510	40	55	65	360	415	8*M16	550	620	40	42	50	300	340	8*M16	637	707	38	38	45	250	280	8*M12
3.26	468	553	40	60	75	360	415	8*M16	579	664	40	48	56	300	340	8*M16	668	753	38	38	45	250	280	8*M12
3.27	523	613	40	60	75	450	500	8*M16	607	697	40	48	56	300	340	8*M16	706	796	38	38	45	250	280	8*M12
3.29	-	-	-	-	-	-	-	-	704	794	40	55	65	360	415	8*M16	814	904	40	42	50	300	340	8*M16
3.31	-	-	-	-	-	-	-	-	734	844	40	60	75	360	415	8*M16	845	955	40	48	56	300	340	8*M16
3.32	-	-	-	-	-	-	-	-	821	956	40	60	75	450	500	8*M16	942	1077	40	55	65	360	415	8*M16
3.33	Available on request																							
3.34	Available on request																							
3.36	Available on request																							
3.38	Available on request																							
3.40	Available on request																							

Installation instructions

The slewing gear needs to be correctly fitted in the machinery bed frame. Locations need to be concentric and square to the ring gear fitting.

The structure must be rigid and sufficiently stiff to resist bending during operation. The table below gives recommended tolerances.

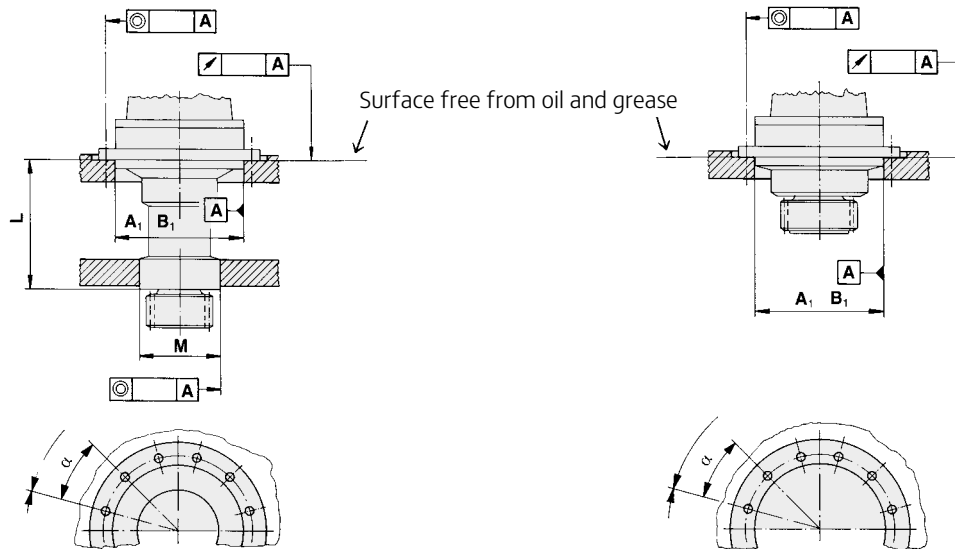

Nominal size	Max. admissible deformations due to external forces							Concentric bores in the assembly, admissible manufacturing					The pinion shaft of the slewing gear must not be deformed inadmissibly by external forces and manufacturing tolerances. Max. admissible tolerances from the centre axis					Nominal size	
	A ₁	A ₂ B ₂ ±	A	A	A ₆	B ₆	α ±	M	Length of output shaft L					Length of output shaft L					
									200	400	600	800	≥ 1000	200	400	600	800	≥ 1000	
3.13	0,09	0,2	0,3	0,05	11	-	15'	0,09	0,05	0,05	-	-	-	0,20	0,20	-	-	-	3.13
3.15	0,10	0,2	0,3	0,05	14	11	15'	0,10	0,05	0,05	0,10	0,10	-	0,20	0,20	0,30	0,30	-	3.15
3.19	0,12	0,2	0,3	0,05	14	14	15'	0,12	0,05	0,10	0,10	0,10	-	0,20	0,30	0,30	0,40	-	3.19
3.20	0,14	0,2	0,3	0,05	14	14	15'	0,14	0,05	0,10	0,10	0,10	0,15	0,25	0,30	0,30	0,40	0,40	3.20
3.22	0,16	0,2	0,3	0,07	18	18	15'	0,16	0,05	0,10	0,10	0,15	0,20	0,30	0,35	0,35	0,50	0,50	3.22
3.24	0,18	0,3	0,5	0,07	18	22	10'	0,18	-	0,10	0,10	0,15	0,20	-	0,35	0,35	0,50	0,50	3.24
3.25	0,20	0,3	0,5	0,07	18	22	10'	0,20	-	0,10	0,10	0,15	0,20	-	0,35	0,35	0,50	0,50	3.25
3.26	0,20	0,3	0,5	0,10	22	22	10'	0,20	-	0,10	0,15	0,20	0,25	-	0,40	0,40	0,60	0,60	3.26
3.27	0,23	0,3	0,5	0,10	22	26	10'	0,23	-	0,10	0,15	0,20	0,25	-	0,40	0,50	0,60	0,80	3.27
3.29	0,25	0,3	0,5	0,10	26	33	10'	0,25	-	-	0,15	0,20	0,25	-	-	0,50	0,60	0,80	3.29
3.31	0,25	0,3	0,5	0,10	26	33	10'	0,25	-	-	0,15	0,20	0,25	-	-	0,50	0,60	0,80	3.31
3.32	0,25	0,3	0,5	0,10	26	33	10'	0,25	-	-	0,15	0,20	0,25	-	-	0,50	0,60	0,80	3.32

Form- and situation tolerances acc. to DIN 7184

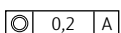

The center line of the tolerated part must be within a cylinder at a diameter of $t = 0,2$, which center line coincides with the center line of the reference plane.

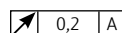

The tolerance of the plane surface must not exceed the tolerance of $t = 0,2$ during one revolution of the workpiece.

Gear reduction ratios

//2-stages – coaxial					
Ratio	17	22	26	30	35
3.13	•	•	•	•	•
3.15	•	•	•	•	•
3.19	•	•	•	•	•
3.20	•	•	•	•	•
3.22	•	•	•	•	•
3.24	•	•	•	•	•
3.25	•	•	•	•	•
3.26	•	•	•	•	•
3.27	•	•	•	•	•
3.29	•	•	•	•	•
3.31	•	•	•	•	•
3.32	•	•	•	•	•
3.33	•	•	•	•	•
3.34	•	•	•	•	•
3.36	•	•	•	•	•
3.38	•	•	•	•	•
3.40	•	•	•	•	•

//3-stages – coaxial										
Ratio	46	61	72	84	94	108	130	148	154	177
3.13	•	•	•	•	•	•	•	•	•	•
3.15	•	•	•	•	•	•	•	•	•	•
3.19	•	•	•	•	•	•	•	•	•	•
3.20	•	•	•	•	•	•	•	•	•	•
3.22	•	•	•	•	•	•	•	•	•	•
3.24	•	•	•	•	•	•	•	•	•	•
3.25	•	•	•	•	•	•	•	•	•	•
3.26	•	•	•	•	•	•	•	•	•	•
3.27	•	•	•	•	•	•	•	•	•	•
3.29	•	•	•	•	•	•	•	•	•	•
3.31	•	•	•	•	•	•	•	•	•	•
3.32	•	•	•	•	•	•	•	•	•	•
3.33	•	•	•	•	•	•	•	•	•	•
3.34	•	•	•	•	•	•	•	•	•	•
3.36	•	•	•	•	•	•	•	•	•	•
3.38	•	•	•	•	•	•	•	•	•	•
3.40	•	•	•	•	•	•	•	•	•	•

//4-stages – coaxial																				
Ratio	199	236	272	322	353	367	418	435	501	542	570	650	676	739	780	886	922	1.007	1.064	1.209
3.13	•	•	•	•	•	•	•	•	•	•	•	•	•	•	•	•	•	•	•	•
3.15	•	•	•	•	•	•	•	•	•	•	•	•	•	•	•	•	•	•	•	•
3.19	•	•	•	•	•	•	•	•	•	•	•	•	•	•	•	•	•	•	•	•
3.20	•	•	•	•	•	•	•	•	•	•	•	•	•	•	•	•	•	•	•	•
3.22	•	•	•	•	•	•	•	•	•	•	•	•	•	•	•	•	•	•	•	•
3.24	•	•	•	•	•	•	•	•	•	•	•	•	•	•	•	•	•	•	•	•
3.25	•	•	•	•	•	•	•	•	•	•	•	•	•	•	•	•	•	•	•	•
3.26	•	•	•	•	•	•	•	•	•	•	•	•	•	•	•	•	•	•	•	•
3.27	•	•	•	•	•	•	•	•	•	•	•	•	•	•	•	•	•	•	•	•
3.29	•	•	•	•	•	•	•	•	•	•	•	•	•	•	•	•	•	•	•	•
3.31	•	•	•	•	•	•	•	•	•	•	•	•	•	•	•	•	•	•	•	•
3.32	•	•	•	•	•	•	•	•	•	•	•	•	•	•	•	•	•	•	•	•
3.33	•	•	•	•	•	•	•	•	•	•	•	•	•	•	•	•	•	•	•	•
3.34	•	•	•	•	•	•	•	•	•	•	•	•	•	•	•	•	•	•	•	•
3.36	•	•	•	•	•	•	•	•	•	•	•	•	•	•	•	•	•	•	•	•
3.38	•	•	•	•	•	•	•	•	•	•	•	•	•	•	•	•	•	•	•	•
3.40	•	•	•	•	•	•	•	•	•	•	•	•	•	•	•	•	•	•	•	•

Other ratios available on request

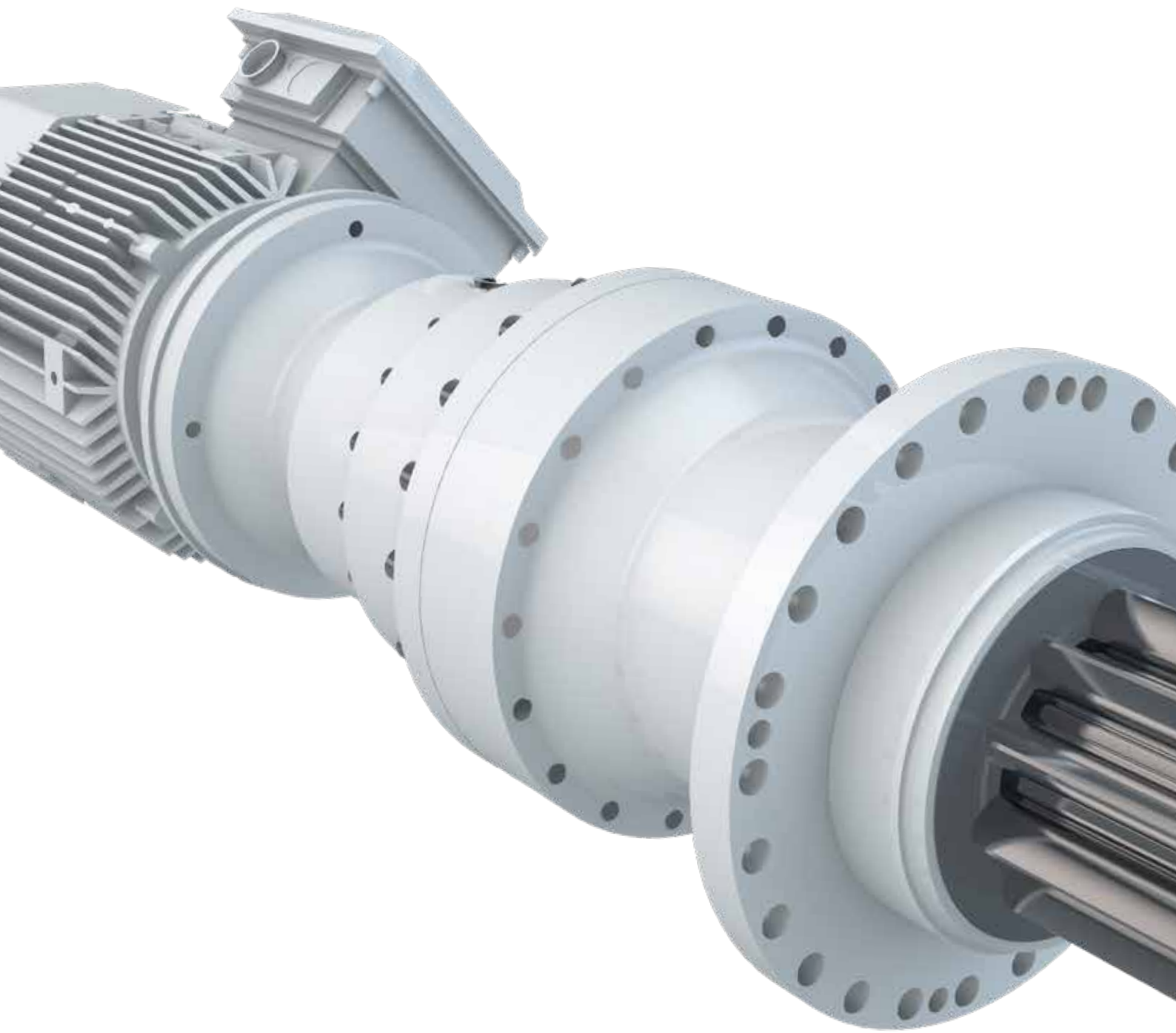

Recommended lubricants for ZOLLERN Slewing gear units

Type/ Specification	Lubricants to DIN 51502			
	Mineral Olic acc. DIN 51 517 T3 CLP 220	Synthetic Lubricants acc. DIN 51 517 T3 CLP HC (PAO) 220	Synthetic Lubricants acc. DIN 51 517 T3 CLP PG 220	Grease acc. DIN 51 825 KP 2 K
Aral	Degol BG 220	-	Degol GS 220	Aralub HLP 2
Avia	Gear RSX 220	Synthogear PE 220	-	-
	-	Avilub Gear PAO 220	Gear VSG 220	Avialith 2 EP
BP	Energol GR-XP 220	-	-	Energrease LS-EP 2
Castrol	Alpha EP 220	Alphasyn EP 220	Alphasyn GS 220	Longtime PD2
	Alpha SP 220	Optigear Synthetic A 220	Alphasyn PG 220	Spheerol EPL 2
	Optigear BM 220	Optigear Synthetic PD 220	Tribol 800/220	Tribol 4020/220-2
	Tribol 1100/220	-	-	-
Fuchs	Renolin CLP 220	Renolin Unisyn CLP 220	Renolin PG 220	Renolit LZR 2 H
	Renolin CLP 220 Plus	-	-	Renolit EP 2
Mobil	Mobilgear 600 XP 220	Mobil SHC 630	Mobil Glygoyle 220	Mobilux EP 2
	-	Mobil SHC Gear 220	-	Mobilgrase XHP 222
Shell	Omala 220	Omala HD 220	Tivela S 220	Alvania EP (LF) 2
	Omala S2 G 220	Omala S4 GX 220	Omala S4 WE 220	Gadus S2 V220 2
Total	Carter EP 220	-	-	Multis EP 2
	Carter XEP 220	Carter SH 220	Carter SY 220	Lical EP 2

Attention: Mineral and PAO-based gearbox oils are not to be mixed with PG (polyglycol)-based synthetic oil. Greases with different soap bases are not to be mixed.

Lubrication frequency

Oil

- 1st oil change after 200 operating hours
- 2nd oil change after 1000 operating hours further oil change after every 1000 operating hours; at least once a year

Grease

- Once a week or on recommissioning

Lubrication type only according indication in the installation drawing resp. in the maintenance manual.

Slewing gears Application Questionnaire

Company/Address _____

Date _____

Proper department _____

Person concerned _____

Number of inquiry _____

Phone _____

Fax _____

e-mail _____

Demand _____

Application (e.g. mobile crane, ship-offshore-harbour cranes, tower cranes) _____

Used for _____

// Operating conditions – Design criteria

Power/Rating

Dynamic load

Output torque T_{dyn} _____ (Nm)

Output speed n_{ab} _____ (rpm)

T_{dyn} is equivalent to $S_{M \max II}$ acc. to FEM Section I

Installed power P _____ (kW)

Static load

Output torque T_{stat} _____ (Nm)

Rating according to FEM Section I

Drive unit class Load conditions Running time class

M L T

Approval acc. to classification society

ABS DNV GL

LRS RMRS Others _____

Alternative rating

Load conditions	T_{dyn} (Nm)	n_{ab} (rpm)	Time slice (%)
1	_____	_____	_____
2	_____	_____	_____
3	_____	_____	_____
4	_____	_____	_____
			100 %

Calculated life time _____ (hour)

Safety against _____ (–)

Yield strength Break

with T_{dyn} T_{stat} _____ (Nm)

// Technical data

Output pinion

Module m _____ (Nm)

Number of teeth z _____ (rpm)

Face width b _____ (rpm)

Addendum modification x _____ (kW)

Standard $x=0,5$ for output pinion

Pinion shaft forged in one piece (standard)

Splined pinion shaft

Hardened and tempered, machined teeth, tooth flank induction hardened, gear quality 9e (standard), ZOLLERN special improved surface finish.

Case hardened with grinded tooth flanks, gear quality 8e

Ring gear

z _____

b _____ (mm)

x _____

Internal teeth

External teeth

Ratio

i _____ \pm _____ %

Flange connection

Flange I Flange II Flange III

Length of

output housing L _____ (mm)

Mounting position

Pinion up down horizontal

// Drive hydraulic motor

Manufacturer _____

Type _____

Available oil flow Q _____ (l/min)

Available differential pressure Δp _____ (bar)

// Drive electric motor

Manufacturer _____

Type _____

Power _____ (kW)

Speed _____ (rpm)

Control (Frequency inverter; ON/OFF; Softstarter)

Voltage, AC/DC _____

Starting torque T_A _____ (Nm)

Breakdown torque T_K _____ (Nm)

Power-on time ED _____ (%)

Starting per hour _____

// Brake

Apply as

Parking brake Service brake

Execution

Spring loaded multi disc brake

with backstop Brake motor

Disc brake Drum brake

Actuation

hydraulically min. release pressure _____ (bar)

electric max. release pressure _____ (bar)

expected back pressure _____ (bar)

// Scope of supply

Motor

Coupling

Incremental encoder

Hydraulic control

Load holding valve

Motor flange

Hydraulic power pack

Approval

Brake for drive unit

Reaction torque arm

Frequency control

Material Certificates

ZOLLERN Group

Product areas

Metals and shaping

// Investment casting parts



- Turbine components
 - Vanes / Blades / Shrouds / Heat Shields
- Structural Castings
 - Gas Turbines / Aero / Engines Defense / Medical / Industrial Components
- Automotive
 - Turbine Wheels / Waste gates / Vanes / Pins / Planet carriers
- Implants
 - Knees (Femur, Tibia) / Hipps
- Alloys
 - Super alloys / Cobalt Chrome alloys



// Sand casting parts



- Sand casting
- Croningguss / Maskenguss
- Ceramic casting
- Continuous casting
- Centrifugal casting



// Forgings



- Forgings made of pure copper and copper alloys
- Semi-finished products, open die forged, flat bars, round bar
- Drop forged parts
- Rings, seamlessly rolled
- Bushings, seamlessly forged
- Individual pieces, small series, large series



// Special profiles and finished parts



- Special profiles, coils, bars
- Customer-specific finished parts
- Profile types hot-rolled, cold-rolled, cold-drawn, induction-hardened



Drive technology and automation

// Gearboxes



- Travel drives
- Slewing gearboxes
- Winch gearboxes
- Industrial gear units
- Gearboxes for tunnel boring machines
- Sugar mill gearboxes
- Electric drive systems
- Condition Monitoring and Predictive Maintenance

// Winches



- Hoisting winches
- Free fall winches
- Pull winches
- Rescue boat winches
- Winch systems
- Winch gearboxes

// Electric motors



- Torque motors kits
- Synchronous motor kits
- Synchronous motor modules

// Automation, special systems

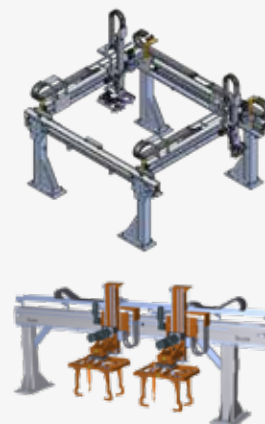

- Linear units, linear modules, gantry axes, portal units
- Telescoping axes
- Rotary modules, rotary tables
- Line gantries, area gantries
- Robot traverse axes, jig axes
- Storey lifter and lifting columns
- Fast conveyor
- Framing tenter handling / overhead systems
- Storage systems
- Complete systems with steel construction and control
- Special solutions
- Gripper

// Hydrostatic systems



- Hydrostatic spindle units
- Hydrostatic rotary tables
- Aerostatic rotary tables
- Hydrostatic linear guides
- Hydrostatic center drive spindles
- Hydrostatic bearing components
- Hydrostatic special applications and test benches

// Rotary tables systems



- Roller bearing rotary tables
- Hydrostatic rotary tables
- Automatic pallet changing systems and linear axes
- Swiveling tables
- After sales service for products of ZOLLERN, Rückle and Eimeldingen

ZOLLERN

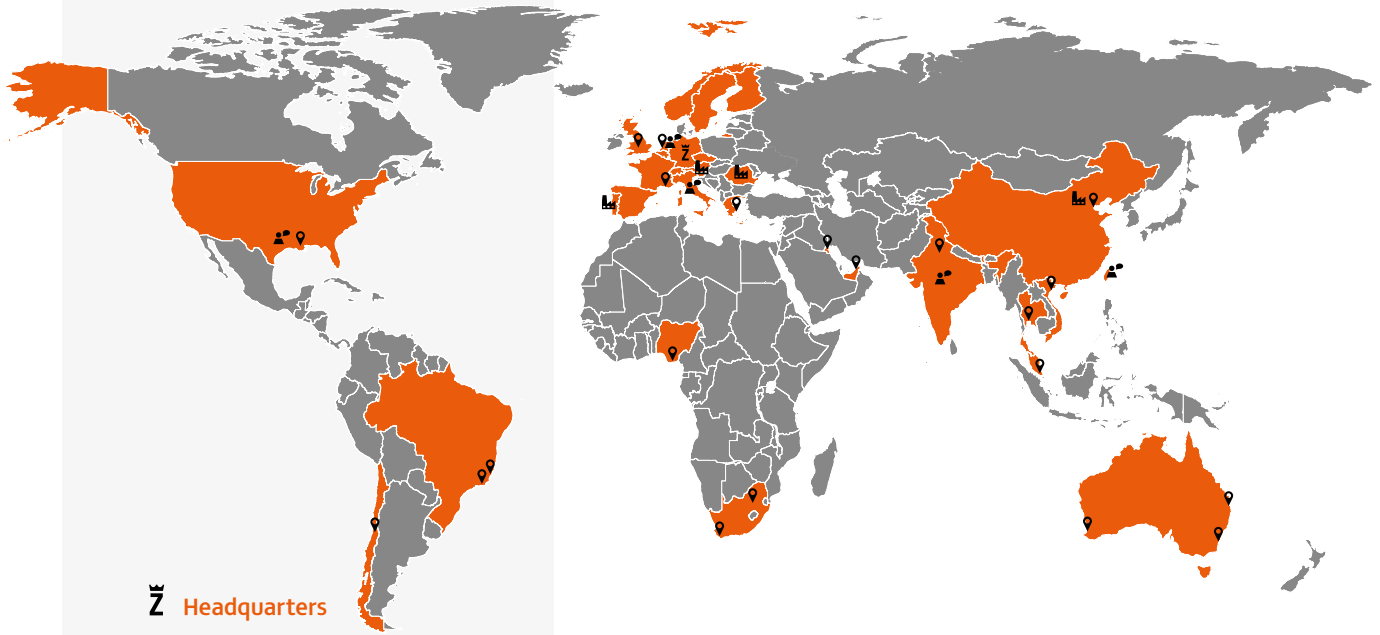

Headquarters

Subsidiaries

Italy and southern Europe
Netherlands and Northern Europe
USA
India and Southeast Asia
Taiwan, China

Factories

Germany
Portugal
Romania
Slovenia
China

Service partner

Australia
Brazil
Chile
Greece
Great Britain
Kuwait
Singapore
South Africa
Thailand
Dubai
USA
Vietnam



ZOLLERN-worldwide



ZOLLERN-Products



ZOLLERN GmbH & Co. KG

Heustrasse 1
88518 Herbertingen
Germany
T +49 7586 959-0
F +49 7586 959-575
zat@zollern.com
www.zollern.com

